

Cleanroom Light Fixtures

Cleanroom Light Fixtures are ideal for general purpose cleanrooms, pharmaceutical cleanrooms and biomedical labs, food processing centers, hospitals and wet locations.

Sealed Housings Maintain Integrity

Totally sealed housings maintain ceiling integrity and protect against infiltration of particles and airborne bacteria. Housings are painted with a white powdercoat finish and spring loaded latches on each side secure the hinged door lens frame in the closed position. The door frame is removable without the use of tools, permitting re-lamping from roomside without contaminating the clean areas.

Features of Standard Fixtures

Standard fixtures feature a 120-277 multi-voltage T8 electronic ballast with (4) medium bi-pin lamp receptacles, (lamps not included). The ballast is mounted inside the housing and is removable from roomside, maintaining ceiling integrity.

Cover for Quick Access

Installation is easy because a gasketed wiring access cover on the top allows quick access for wiring to the building power source.

Compliance with Federal Standards

These luminaries are UL listed and manufactured in accordance to USDA, FDA, and NSF guidelines. All fixtures have been tested and reported in compliance with Federal Standard 209 and are suitable for Class 1,000 to 100,000 or ISO Class 3 to 9 Cleanrooms. Consult with the factory for Class 100 or ISO Class 1 and 2 applications or hazardous location fixtures.

Emergency Battery Pak

All models are available with an Emergency Battery Pak. In the event of a power failure, a fixture equipped with this option will illuminate a single lamp, 350-450 lumens for up to 90 minutes.

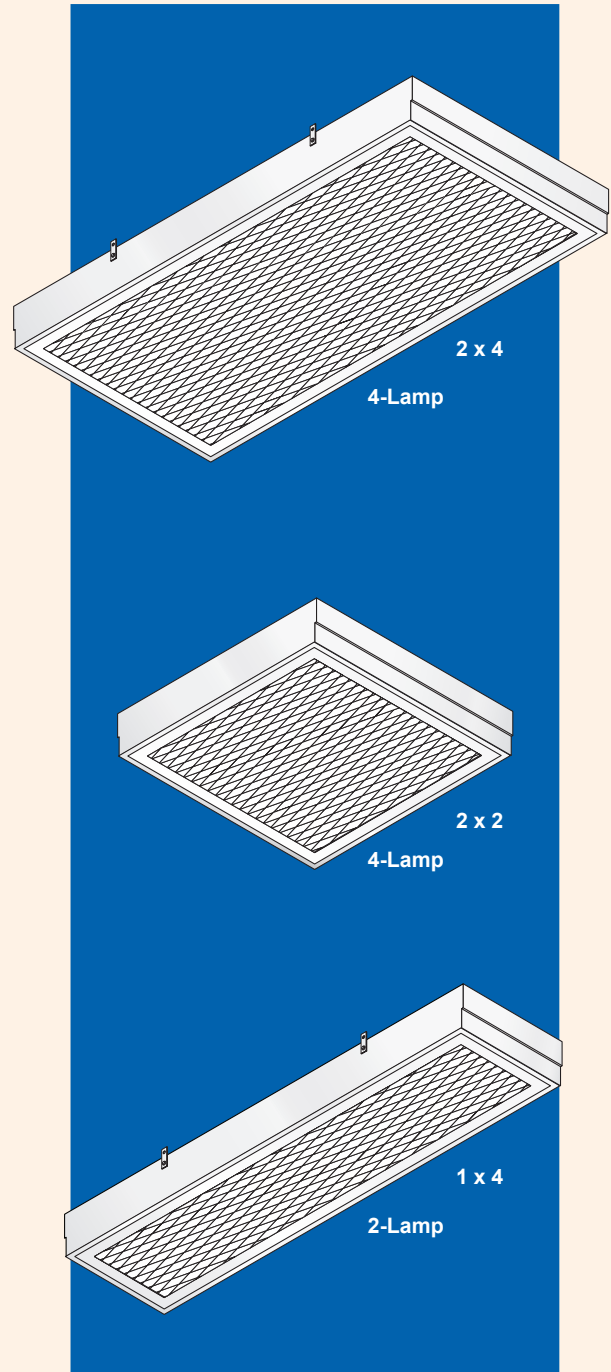

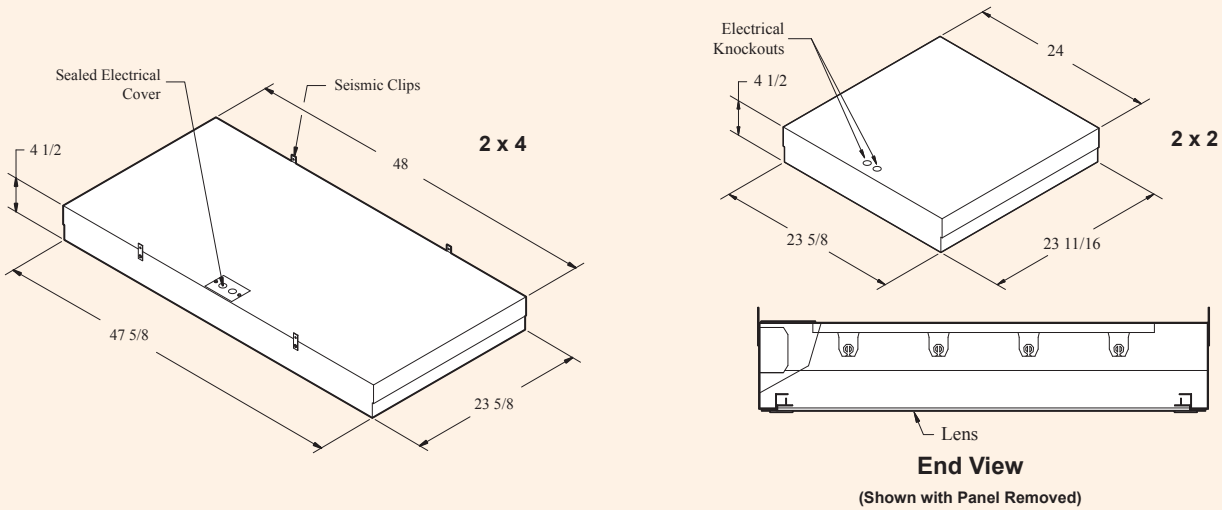

Door Frame and Lens

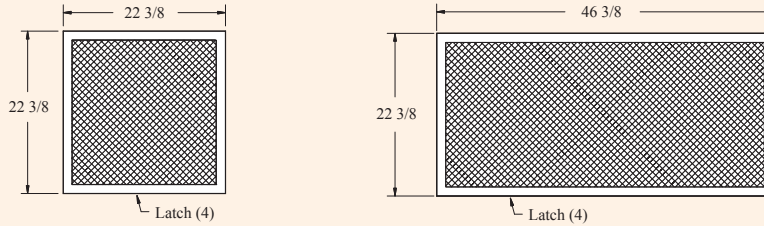

Standard 2 x 4 Fits These T-Grid Openings

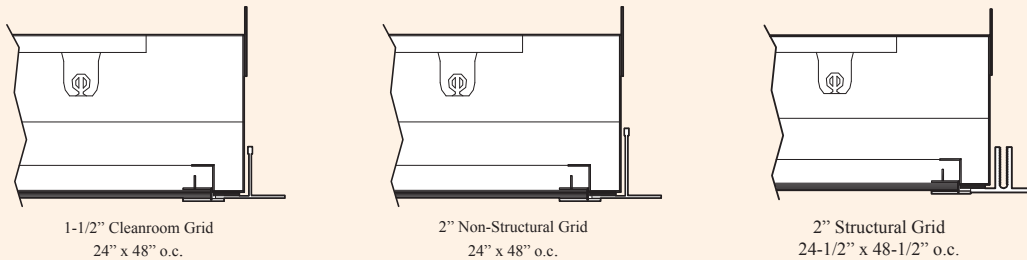

Consult with factory when using 2" HD Grid on 2' x 4' centers.

Ordering Information								
Part No.	Nominal Size	Voltage	Cycle	Lamp	Ballast	Amps	Watts	Weight
148050	2 x 4	120V - 277V	50/60 Hz	4 Lamp	T8 Electronic	*1	32 / 128	35 lbs. (16 kg.)
148053	2 x 2	120V - 277V	50/60 Hz	4 Lamp	T8 Electronic	*2	17 / 68	23 lbs. (11 kg.)
148066	1 x 4	120V - 277V	50/60 Hz	2 Lamp	T8 Electronic	*3	32 / 64	25 lbs. (12 kg.)
148513	Door Frame and Lens							
703902	Optional 8' Power Cord 110V-120V Only							
148075	Emergency Battery Pack 120V							
148084	Emergency Battery Pack 277V (2 x 2 and 2 x 4 Only)							
703754	Ballast 120V-277V Multi-Voltage							

*1. 120V = .93 amps, 277V = .40 amps

*2. 120V = .94 amps, 277V = .40 amps

*3. 120V = .50 amps, 277V = .21 amps